

VA08-BP70/LL-23A
VA08-BP70/LL-23S

24v c.c. - D.C.

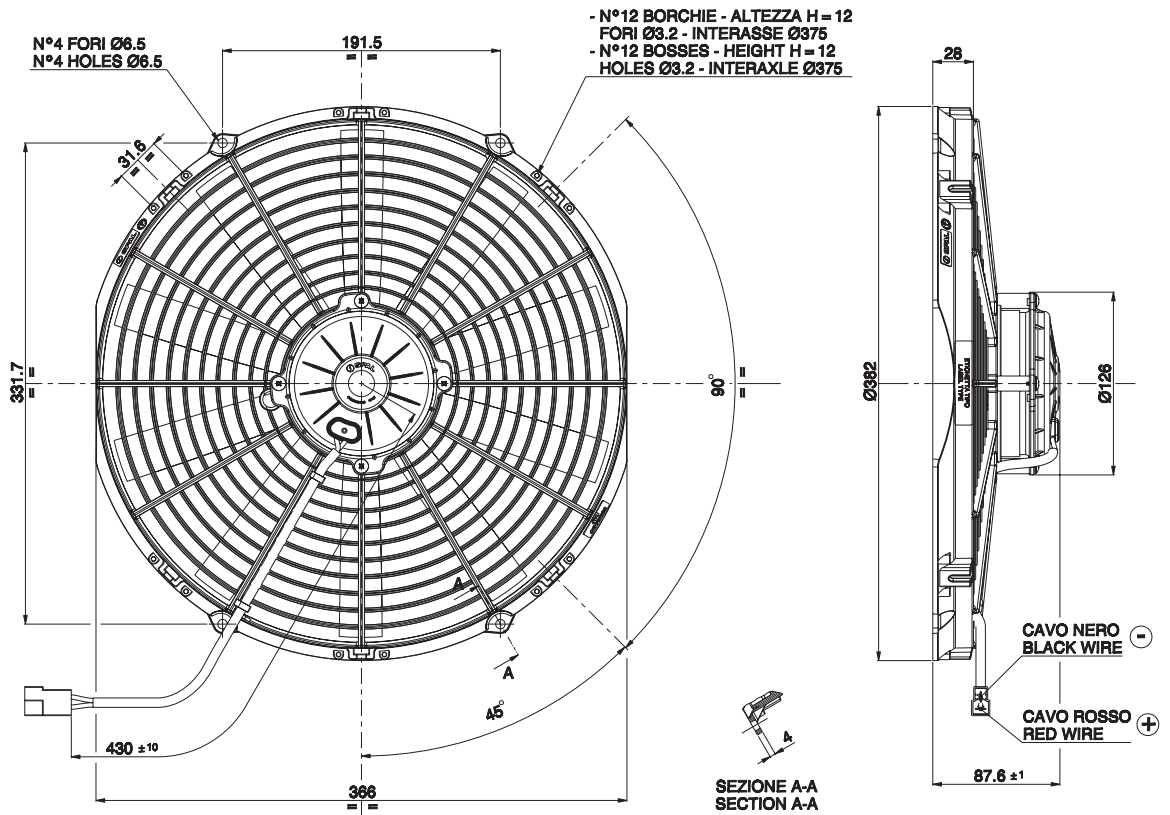

Ø 350 mm

Ø 14"

AMP connector Code 180908
AMP terminal Code 42098-2
Suggested mounting torque: 3(+1/-0) Nm with screw M5
Weight 2,34 Kg. approx.

Connettore AMP Cod. 180908
Terminali AMP Cod. 42098-2
Coppia di serraggio consigliata: 3(+1/-0) Nm con vite M5
Peso 2,34 Kg. circa

PRODUCT FEATURES
CARATTERISTICHE PRODOTTO

suction / aspirante

blowing / soffiante

Waterproof motor, IP 68
Motore chiuso, IP 68



Long life / Lunga durata



VLL version* / Versione VLL*



Waterproof connector
Connettori a tenuta stagna



Accessories: all the fixing kits
Accessori: tutti i kit di fissaggio



Static pressure Pressione statica mm H ₂ O	suction / aspirante		blowing / soffiante		Static pressure Pressione statica inH ₂ O
	Airflow Portata m ³ /h	Current input Corrente assorbita A	Airflow Portata CFM	Current input Corrente assorbita A	
0	2580	7,2	1522	6,6	0
5	2250	7,6	1328	6,9	0,2
10	1820	7,9	1074	7,2	0,4
12,5	1670	7,9	985	7,3	0,5
15	1440	7,8	850	7,4	0,6
17,5	1100	7,4	649	7,3	0,7
20	940	7,5	555	7,4	0,8
25	490	7,4	289	6,9	1
30	0	7,6	0	6,9	1,2

* for OEM applications only.
* per applicazioni OEM

✓ = Standard feature
Caratteristiche standard

✓ = Available upon request
Disponibile su richiesta

Test voltage 26 V. D.C. - Tensione di prova 26 V. c.c.